

Cuaderno:

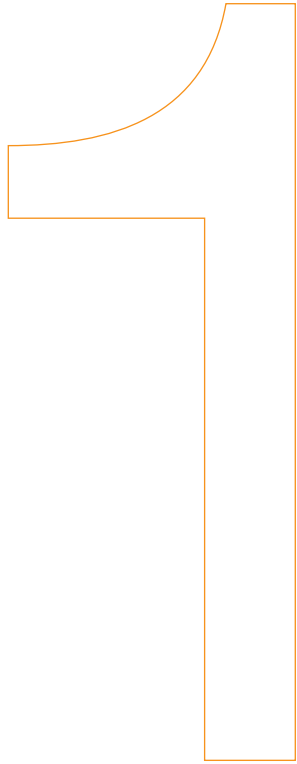

Nombre:

Fecha:

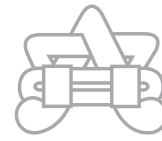

# Dibuja y aprende

con la Colección de Arte Prehispánico  
del Museo Amparo



**Museo Amparo**

¡Bienvenido!  
Te invito a descubrir el  
México antiguo a través  
de la Colección de Arte  
Prehispánico del Museo  
Amparo.

Colorea los dibujos.  
Encuentra la imagen que  
corresponde a cada pieza,  
recórtala y pégala en la página  
correspondiente.



Compártenos tus  
dibujos con el hashtag  
#ElAmparoentuCasa  
en Facebook, Twitter o  
Instagram

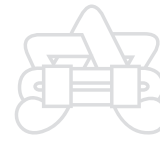



¡A empezar!



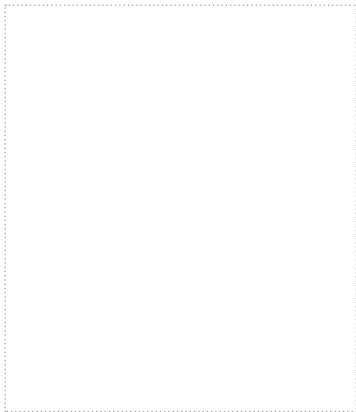

La casa prehispánica en náhuatl se dice *calli*

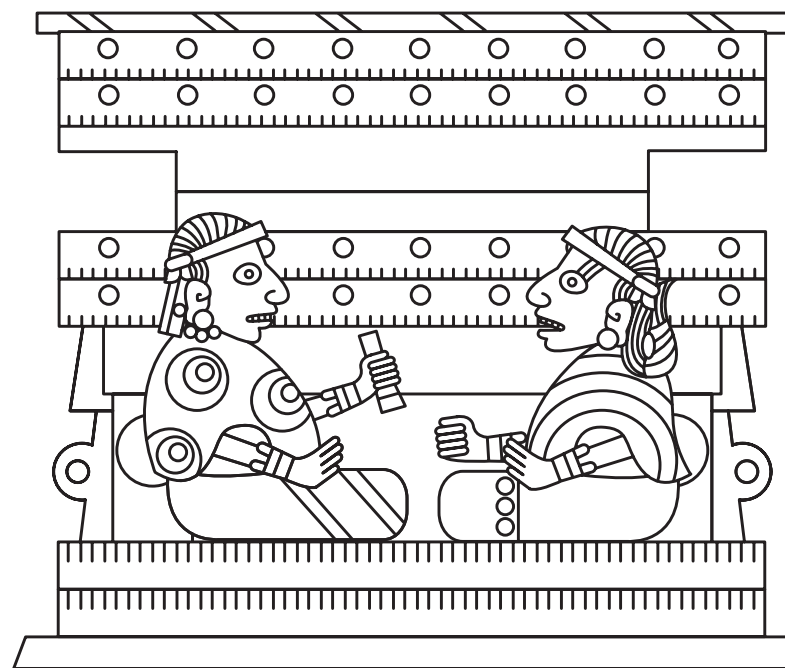

En el *teocalli* o templo vivían los sacerdotes

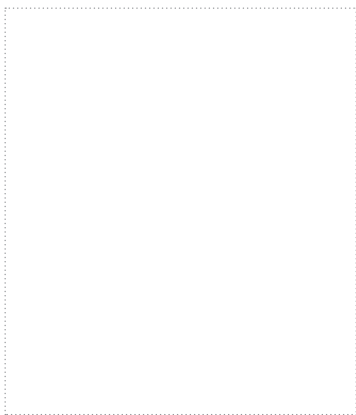

La serpiente está asociada a la tierra,  
la fertilidad y lo femenino

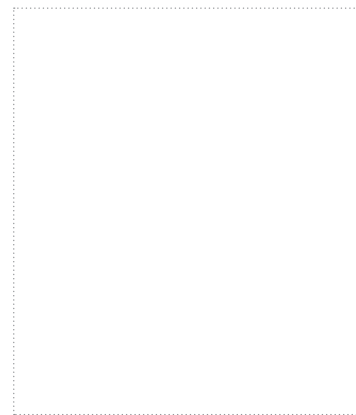
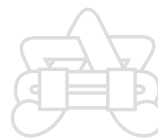

*Napatecuhtli*, el guardián de las cuatro  
esquinas del cosmos

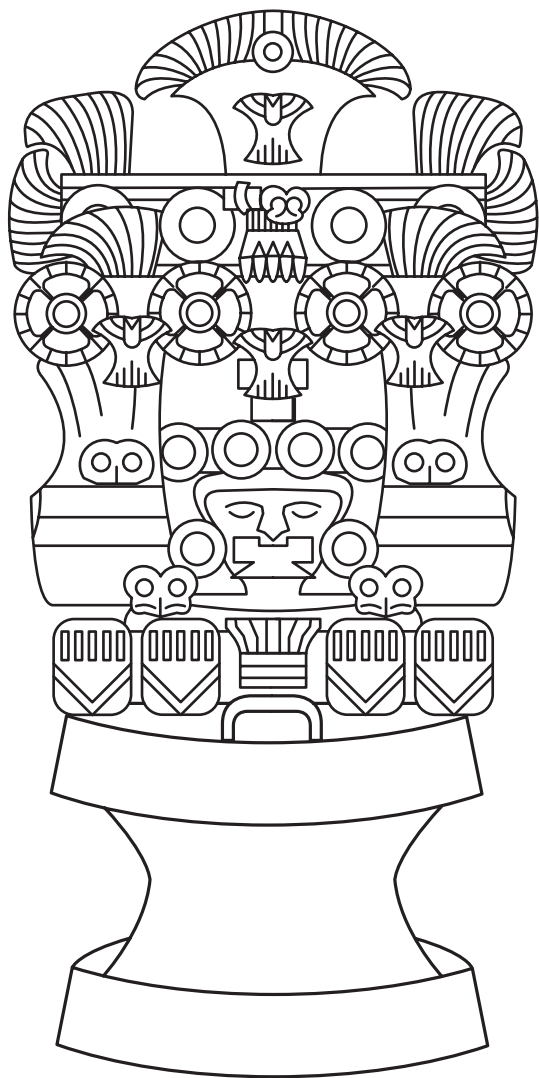
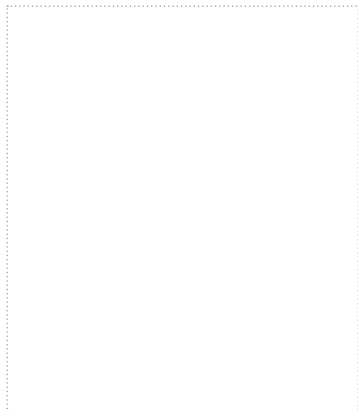

En Teotihuacán, los braseros se ocupaban para las ceremonias a los dioses; esta tapa servía para cubrir un recipiente donde se quemaban ofrendas y copal

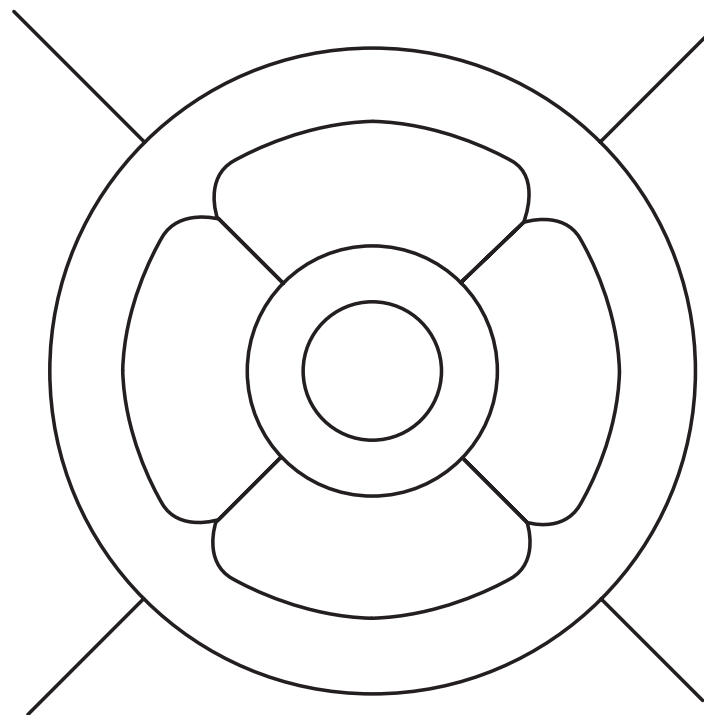
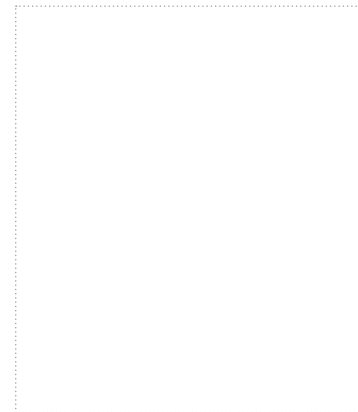

Para los hombres prehispánicos, la tierra era plana y cuadrada, tenía cuatro rumbos o esquinas y un centro

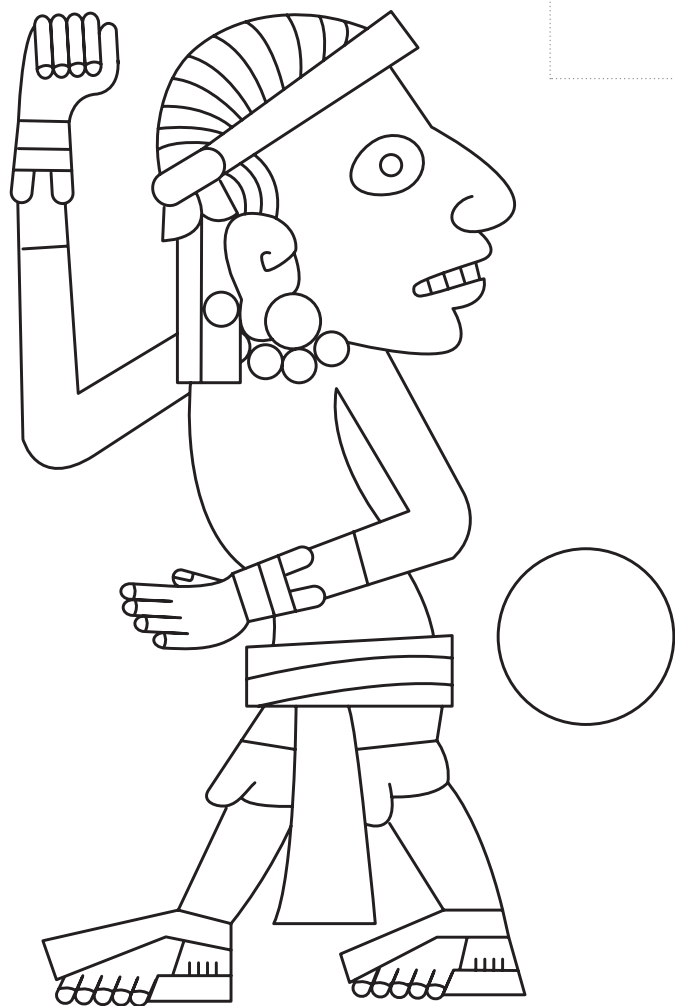

Los jugadores de pelota usaban protectores llamados yugos en su cintura para golpear la dura pelota de hule

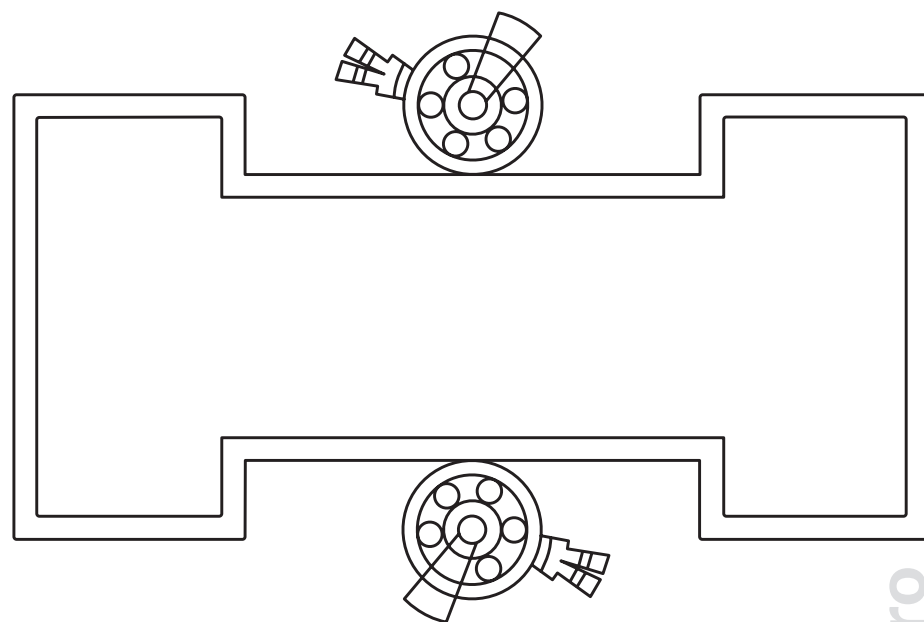
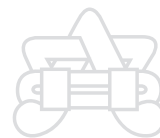

Las canchas de juego de pelota simbolizaban el cosmos, entonces el movimiento de la pelota representaba el tránsito del sol por el cielo